



@BotswanaBMEE expo



Botswana Mining & Energy - BME



Botswana Mining & Energy - BME



Botswana Mining & Energy - BME

# BOTSWANA MINING & ENERGY

# BME

## CONFERENCE & EXPO

### EVENT BROCHURE

22 - 23 March 2023

Gaborone, Botswana

[www.bwminingandenergy.com](http://www.bwminingandenergy.com)



SUPPORTED BY

ORGANISED BY



# EXPLORE BOTSWANA

## THE FOREMOST SOUTHERN AFRICAN FORUM FOR THE GLOBAL MINING & ENERGY STAKEHOLDERS OF THE BOOMING ECONOMY OF BOTSWANA

**Botswana Mining & Energy Conference and Exhibition** is the region's latest international mining, renewables, power & construction expo and gathering of top mining, power & energy executives, representatives of regional executive authorities, investors, banks, industry associations, service companies and equipment producers for two days of networking, knowledge sharing and business matching.

The event has separate 2 days conference, with free-to-attend exhibition, hosting the region's leading mining, energy, technology & service providers.

## TOP 3 REASONS TO BE PART OF BOTSWANA MINING & ENERGY

- 1** Region's latest international platform solely dedicated to mining, renewables, power & construction
- 2** Enhance your visibility in front of 700 business professionals in Botswana
- 3** Attracts decision makers from 20+ countries across the mineral & energy resources value chain

## SHOW HIGHLIGHTS

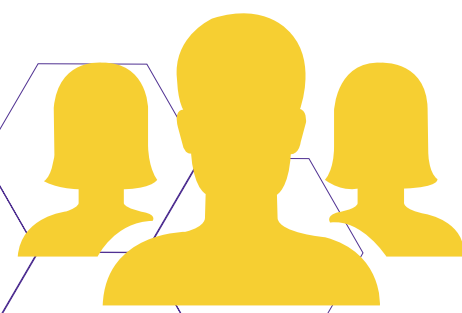

**700+**

**ATTENDEES**



**100+**

**DELEGATES**



**50+**

**EXHIBITORS**



**35+**

**SPEAKERS**



**1**

**UNMISSABLE  
SHOW**

# ATTEND

## CAPITALISE ON THE NEW MARKET OPPORTUNITIES IN BOTSWANA AS THE COUNTRY IS EMERGING AS PREFERRED INVESTMENT DESTINATION FOR MINING, ENERGY, POWER & CONSTRUCTION COMPANIES

- Mining and Energy Ministers & Department Heads
- Company C Level Executives & Senior Management
- Utilities and IPP's
- COOs & Chief Engineers
- EPC's & Project Developers
- Renewable Energy Operators & Manufacturers
- Investors, Financiers, Banks & Insurance Providers
- Lawyers, Brokers, Corporate Advisors & Consultants
- Equipment Solutions & Services Professionals
- Local distributors and resellers



### 20 COUNTRIES REPRESENTED

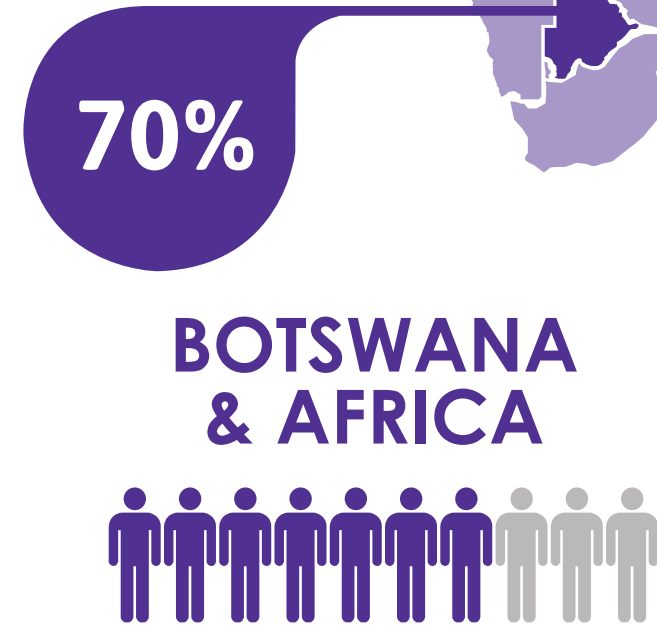
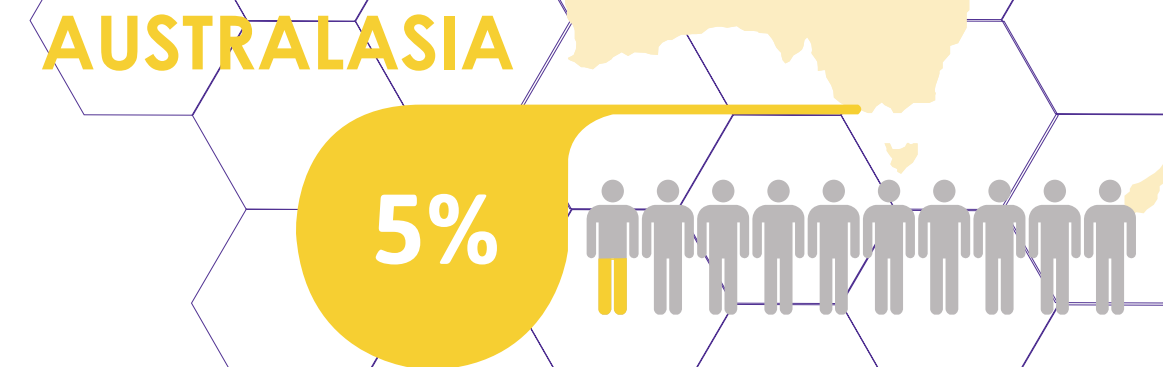

### TOP DECISION MAKERS ATTENDING THE EVENT

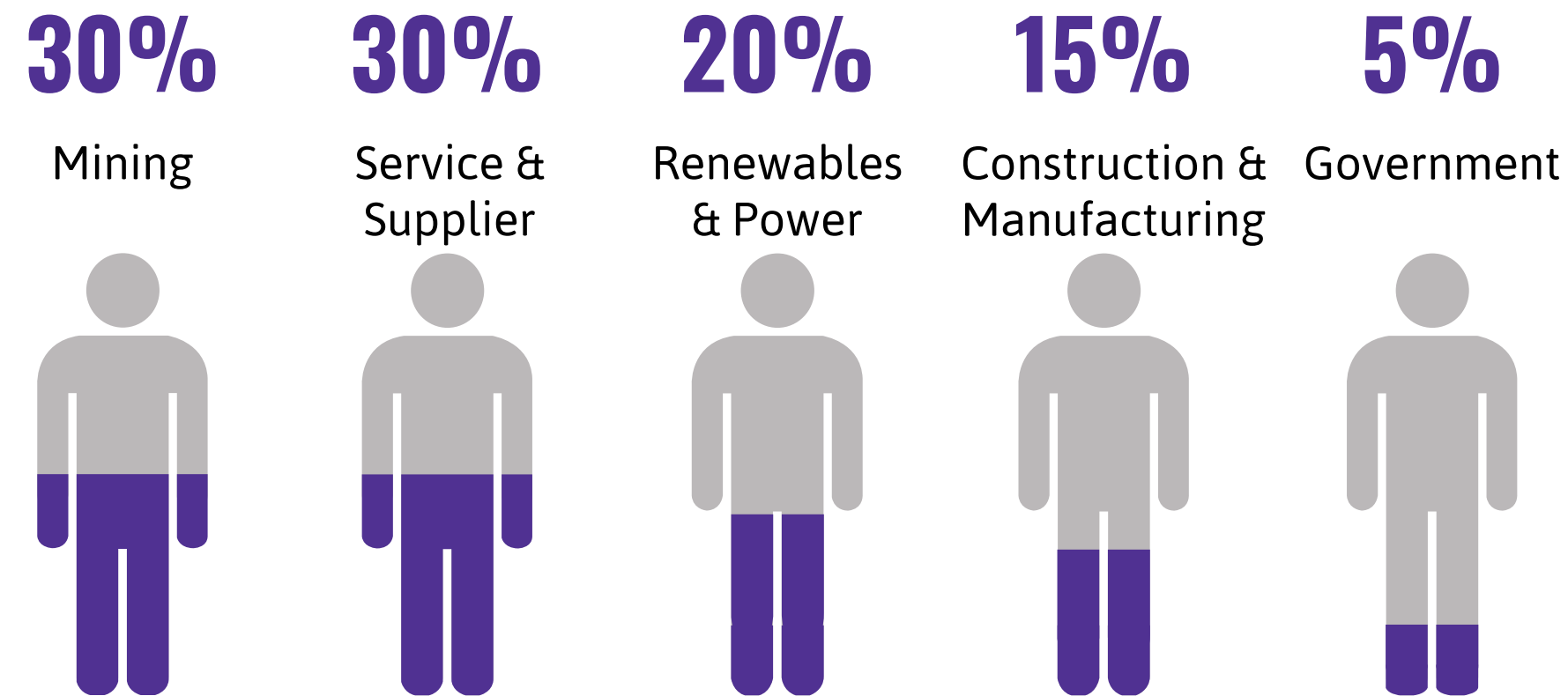

**WHO EXHIBITS |  
MINING**

**WHO EXHIBITS |  
RENEWABLES, POWER & CONSTRUCTION**

**WITH OVER 50 EXHIBITORS AND 700 ATTENDEES, THIS IS YOUR ONE-STOP  
SHOP FOR PRODUCT DEMONSTRATIONS AND NETWORKING**



**Governments  
& Investment  
Promotion  
Boards**



**Developers,  
Explorers &  
Juniors**



**Mid-Tier &  
Major Mining  
Companies**



**Mining &  
Engineering  
Consultants**



**Banks &  
Financial  
Services Firms**



**Midstream &  
Downstream  
Operators**



**Power  
Generation  
Equipment**



**Transmission &  
Distribution  
Providers**



**Solar  
Energy  
Companies**



**Clean  
Technology &  
Wind Turbines**



**Legal Firms**



**Mine  
Production,  
Processing and  
Exploration  
Services**

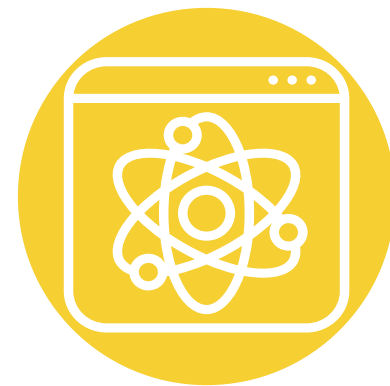

**Technology  
Developers**



**Heavy  
Equipment &  
Machinery  
Suppliers**



**Other Mining  
& Metals  
Solutions  
Providers**



**Energy Storage  
Solution  
Providers**



**Construction &  
Materials  
Handling**



**Smart Energy  
Solution  
Providers**



**EPCs,  
Developers &  
Engineering  
Services**



**Services,  
Technology &  
Equipment  
Manufacturers  
& Consultants**

Officially supported by



# EXHIBITOR PACKAGES

## EXAMPLE OF SHELL SCHEME PACKAGE

### STAND DESCRIPTION

## SHELL SCHEME PACKAGES STAND

The package per 9m<sup>2</sup> stand contains the following:

- Table & Chairs
- Carpet
- Electricity plug points
- Fascia board with your company or product name
- Spotlights
- Walling up to 3 sides
- Logo & description on website
- Logo & description in event guide

All other items are the responsibility of the exhibitor, and can be ordered via the forms made available in this manual.

*Shell Scheme USD \$400/sqm (Minimum 9 sqm)*

## RAW SPACE

The raw space options contains:

- Space only

*Raw Space USD \$360/sqm (Minimum 18 sqm)*

**CLICK HERE TO BOOK YOUR STAND NOW!**

**DANIEL.RADZ@SPIRE-EVENTS.COM**

**ANUCITA.CYNTHIA@SPIRE-EVENTS.COM**

### PERSPECTIVE

FASCIA BOARD - DISPLAYS EXHIBITORS NAME OR PRODUCT NAME

WHITE SHELL SCHEME WALLING, 2.5M IN HEIGHT - SIDE & REAR (DEPENDING ON POSITIONING & REQUIREMENTS)

CARPET

TABLE & CHAIRS



### PLAN VIEW

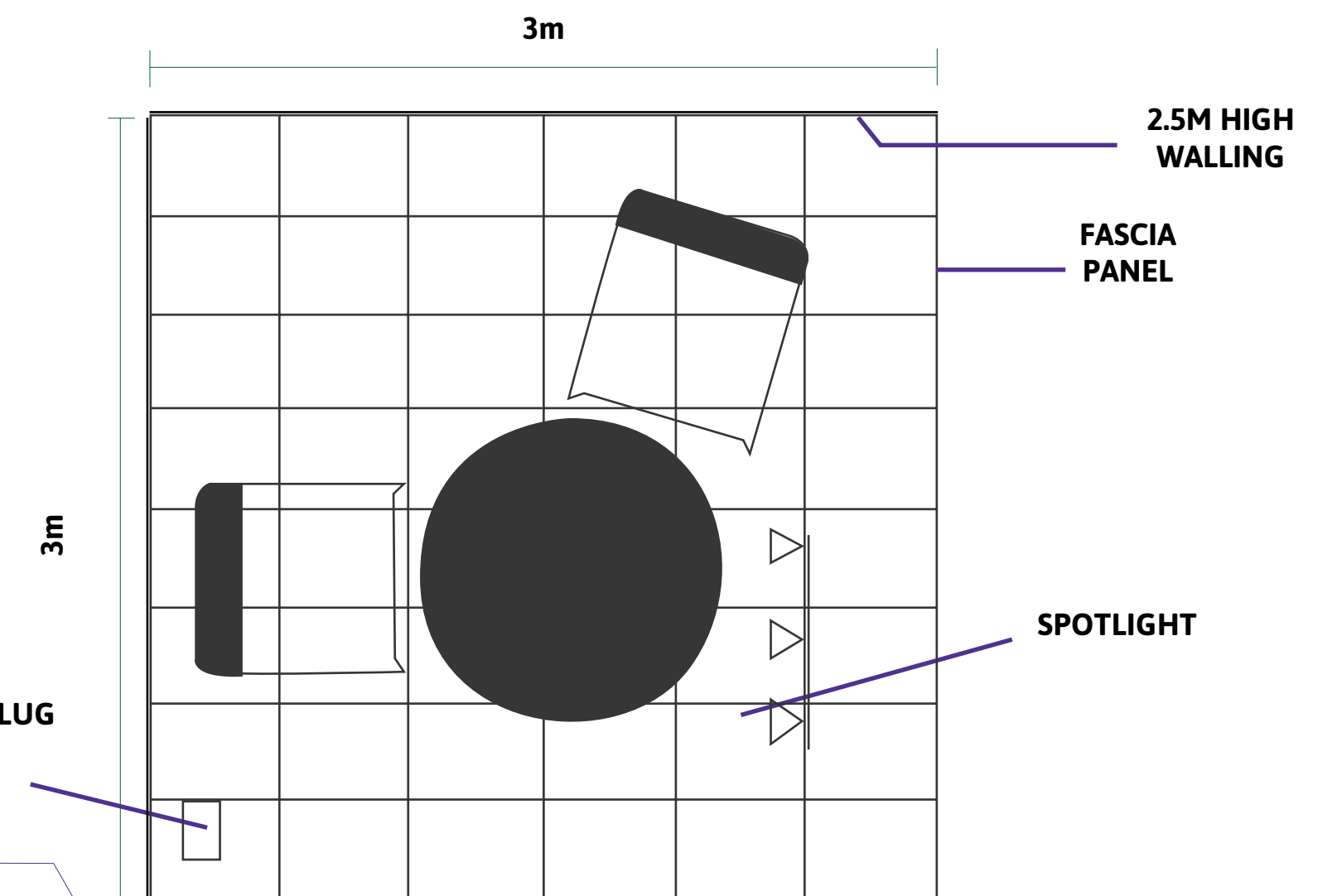

# WHY YOU SHOULD EXHIBIT

1

**Generate new leads:** Meet buyers and decision makers from the region's mining, energy, power and construction industries

2

**Brand your company:** Enhance your visibility and benefit from growing investments in the mining and energy industries

3

**Open doors to new market:** Engage with distributors, partners or agents to expand your business in Botswana and the region

4

**Reliable global exhibition and conference organiser:** Spire Events is a leading global events organiser with established mining investment and technology conferences across Africa and beyond

5

**On the ground expertise:** We have experienced local teams in Botswana who ensure you get maximum results from this event with minimum hassle

6

**Regional experience:** We have been organising mining & energy events across Africa

# BUSINESS MEETING TOOL

## BUSINESS MATCHING MADE SIMPLE & CONVENIENT



We are providing our web based one-on-one meeting planner tool for you to easily identify the right attendees and arrange the desired meetings according to your time and schedule. Choose whom you want to accept meeting requests from and search for fellow attendees based on region, industry etc. It is user friendly for desktops, tablets and mobiles and our team is always an email away to provide you with any technical support.

### Dedicated Meeting Area

Delegates will be able to schedule their 30 minute meetings in the dedicated meeting area or any area at the venue that works best for you.

### Your Individual Schedule

See at a glance your schedule of meetings for the day and choose to receive alerts on your phone or email when you are due for the next meeting to avoid missing any appointments.

# CONNECT AND SHARE

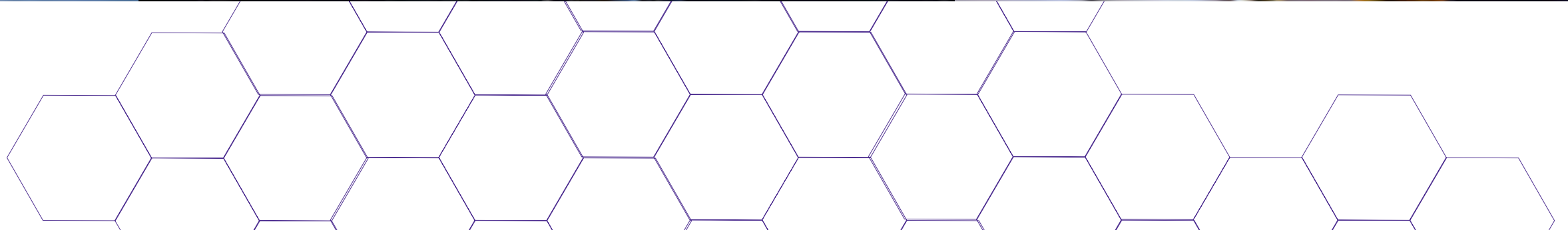

# CONNECT AND SHARE

## TECH SHOWCASE



## 1-2-1 MEETINGS



## DISCUSSIONS

## INTERVIEWS

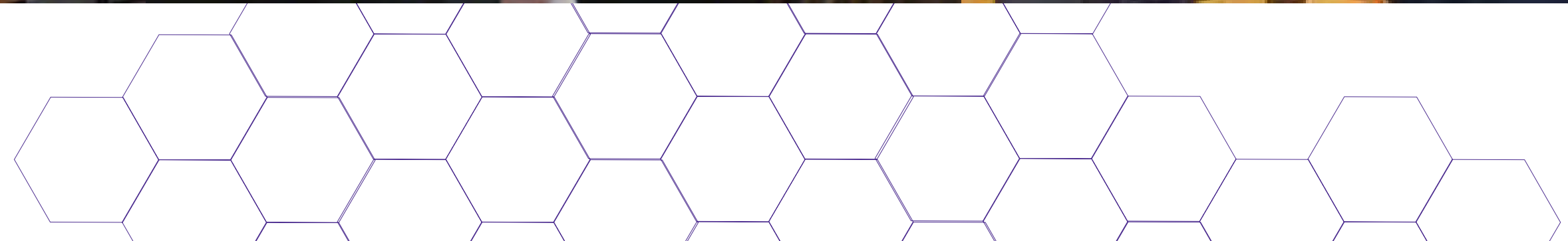



# CONFERENCE

## TECHNOLOGY, INFRASTRUCTURE & INVESTMENT – THE FUTURE OF MINING AND ENERGY IN BOTSWANA

**THE PREMIER BOTSWANA MINING & ENERGY CONFERENCE AND EXHIBITION FOCUSES ON THE MINERAL RESOURCES, ELECTRICITY & POWER GENERATION MARKET AS WELL AS RENEWABLE ENERGY OPPORTUNITIES, CHALLENGES & PERSPECTIVES.**

**THE EVENT ADDRESSES THE NEW DIRECTION FOR THE MINING AND ENERGY INDUSTRIES TO MOVE FORWARD, PRESENTS MARKET INVESTMENT DEVELOPMENT OPTIONS, ENHANCED GOVERNMENT POLICIES AND NEW REGULATIONS.**

Botswana Mining & Energy Conference and Exhibition brings together the most influential & innovative minds to establish itself as leading mining, energy, construction & power investment and technology showcase platform in the region. Our inspirational keynotes and pioneer speakers provide latest industry knowledge and tips for the changing industry across the globe.

**Meeting platform for power and resources companies CXOs, ministers, investors, technology leaders & other industry experts in Africa.**

### WANT TO GET INVOLVED?

Speaking opportunities to potential investors and lead positions are limited & only available for silver sponsors and above. These are allocated on a first come first serve basis!

Call Cynthia on +91 91235 34429 |  
[anucita.cynthia@spire-events.com](mailto:anucita.cynthia@spire-events.com)

**From keynote presentations, practical case studies and tech spotlights to interactive roundtable discussions and workshops, Botswana Mining & Energy gives you the opportunity to showcase your expertise in a multitude of formats.**

### CONFERENCE TOPICS HIGHLIGHTS:

- Making Botswana more attractive destination for mining investment
- Exploring opportunities for the electricity sector
- Energy industry market challenges and opportunities from downstream to midstream
- Renewable energy perspectives including solar, hydro and wind power
- Special outlook on copper, nickel, coal, diamond, gold, cobalt, bauxite, salt, iron ore and manganese
- Deriving optimal benefits for investors and country from the extracting, processing and exporting of these minerals
- Improving energy access and developing infrastructure (bridges and road networks, electricity, water supply and communication systems)
- Establishing a comprehensive governance framework for the mining & energy sectors
- Updates on regulations and industry standards
- Introducing smart electricity solutions
- Energy storage applications
- Building trust and confidence of foreign investors – roles played by government and industry players
- Latest technologies in mining & energy industries
- Occupational safety & health hazards
- Business partnerships - finding out the solution for success in company collaborations
- Sustainable development and environment

**BOTSWANA MINING & ENERGY**  
**BME**  
**CONFERENCE & EXPO**

# SPONSORSHIP OPPORTUNITIES

## ADDITIONAL BRANDING AND PROFILING OPPORTUNITIES

Aside from the above, below are a selection of additional branding and profiling opportunities that are available to either add onto one of the above sponsorship options or can be created as a bespoke package that best suits your needs.

PACKAGE / BENEFITS	LEAD	PLATINUM	GOLD	SILVER	ASSOCIATE	EXHIBITOR
<b>Content and Industry Thought Leadership</b>						
Keynote speaker slot (30 minutes)	1					
An opportunity to chair sessions, moderate or join a panel	2	1	1	1		
Premium speaker slot (20 minutes) - Day 1		1	1			
Premium speaker slot (20 minutes) - Day 2	1			1		
Tech speaker slot (10 minutes)					1	
<b>Partnering Benefits</b>						
Assistance with pre-arranging meetings	Yes	Yes	Yes	Yes		
Delegate passes	15	10	6	4	2	2
Exhibition passes	8	4	3	2	1	1
Use of networking platform	Yes	Yes	Yes	Yes	Yes	Yes
Exhibition Stand	18 sqm	18 sqm	12 sqm	9 sqm	9 sqm	9 sqm
<b>Branding and Profiling Benefits</b>						
Website listing - profile and logo	Yes	Yes	Yes	Yes	Yes	Yes
Visitor show guide listing - logo	Yes	Yes	Yes	Yes	Yes	Yes
Visitor show guide listing - profile	350 words	250 words	150 words	100 words	50 words	50 words
Visitor show guide - advert	2 pages	1 page	1/2 page	1/4 page		
Conference brochure - advert	2 pages	1 page	1/2 page			
Sponsorship inserts in the delegate packs	Yes	Yes	Yes			
Logo on either side of exhibition floor entry area	Yes	Yes				
Logo on backdrop of the main conference room	Yes	Yes	Yes	Yes	Yes	
<b>Lead Generation Benefits</b>						
Content email shot	2	2	1			
<b>Opportunity to Choose of the following Add Ons</b>						
Coffee break one day, lunch sponsor one day, pens	Yes	Yes				



**SESSION SPONSOR**



**NETWORKING DRINKS SPONSOR**



**EXHIBITOR**



**VIP SPEAKER ROOM**



**LANYARD SPONSOR**



**WIFI SPONSOR**



**COFFEE BREAK SPONSOR**



**LUNCH & GALA DINNER**



**EVENT FOLDER SPONSOR**



**WATER BOTTLE SPONSOR**

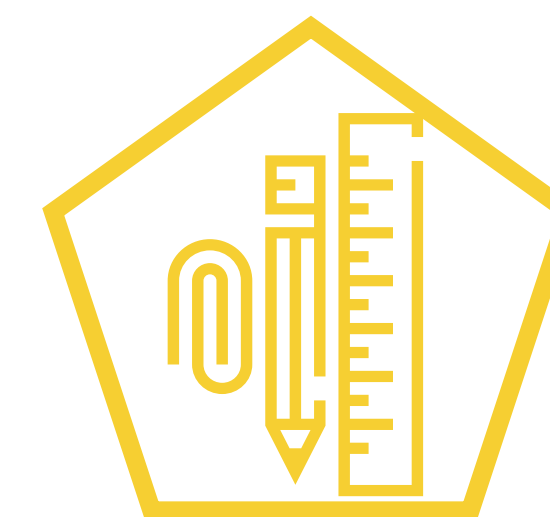

**STATIONERY & BAG SPONSOR**

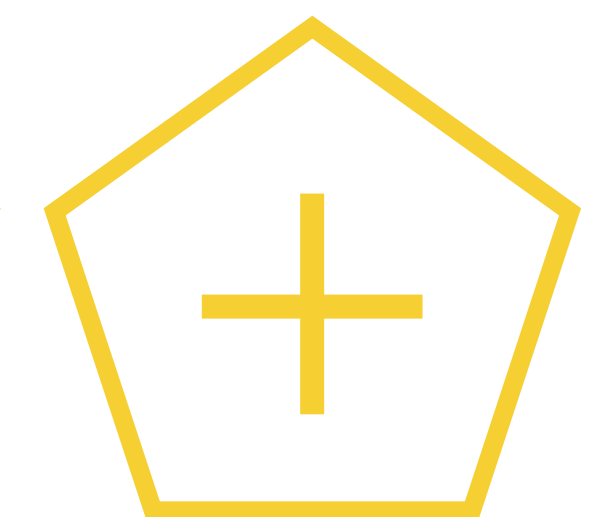

**MORE!**

**CALL NOW!**

**daniel.radz@spire-events.com | +65 9649 1062**

# HOW WE TARGET BUYERS

## A MARKETING & PR CAMPAIGN THAT SPANS MONTHS

We continually engage with our community of industry professionals.

 **40,000** Emails sent

 **10** Trade Publication Campaigns

Our marketing campaign comprises of:

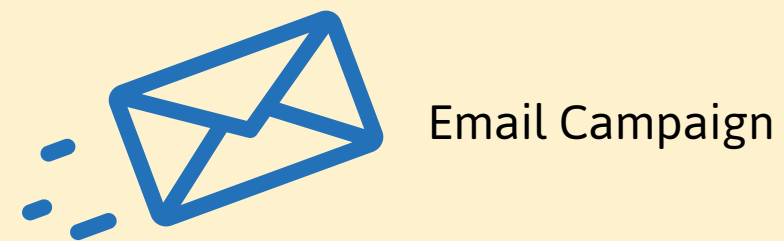

Email Campaign



Print and Web



Partners

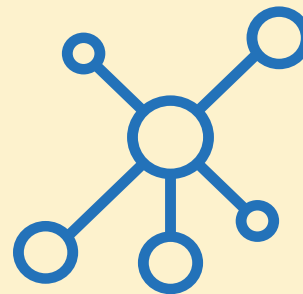

Social Media



Telemarketing



TV and radio

## BOOK YOUR STAND

**DANIEL RADZ**

Director

Phone: +65 9649 1062

Email: daniel.radz@spire-events.com

**ANUCITA CYNTHIA**

Manager, Business Development

Phone: +91 91235 34429

Email: anucita.cynthia@spire-events.com

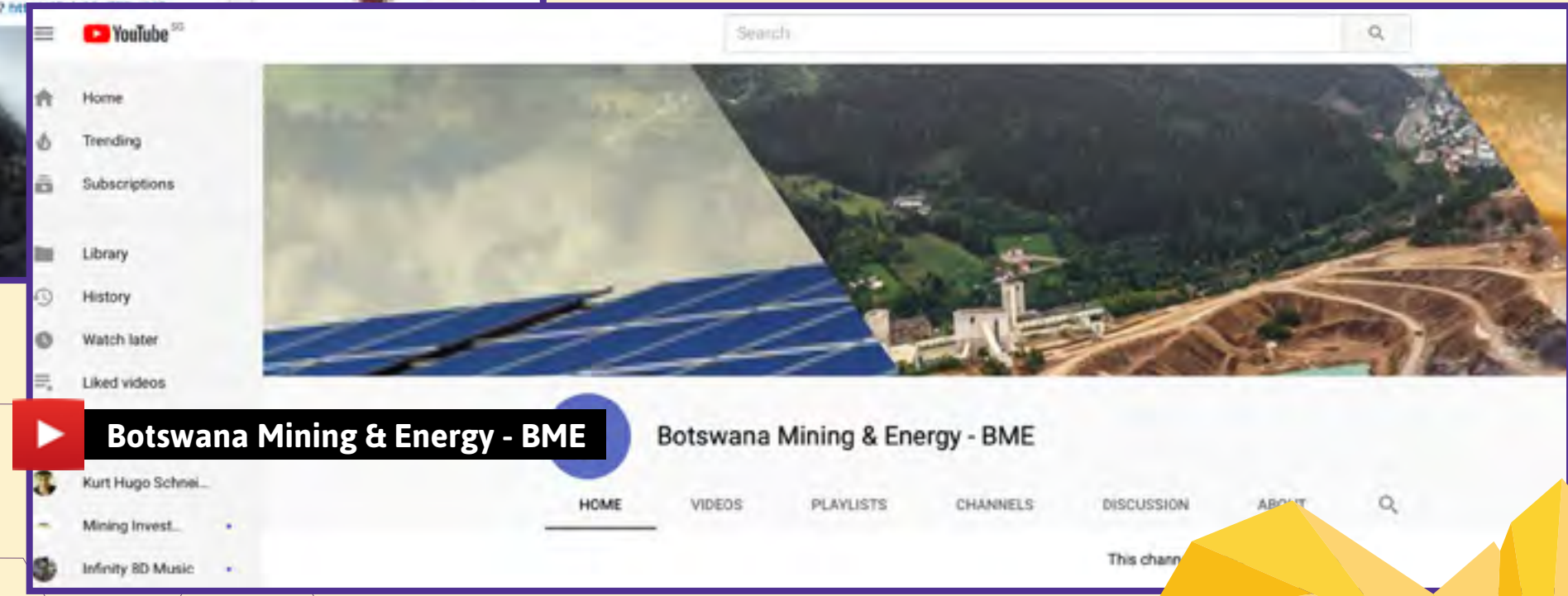
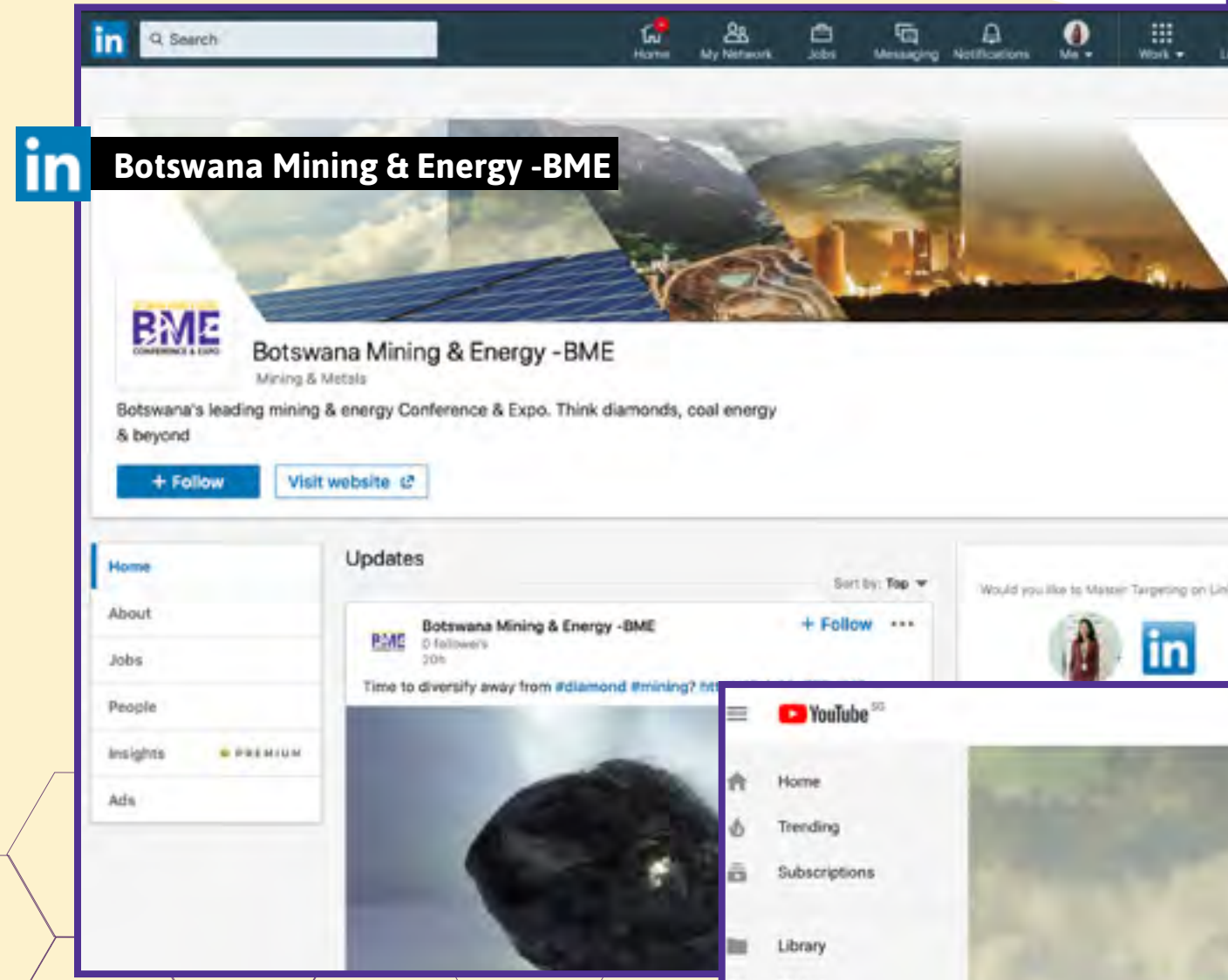
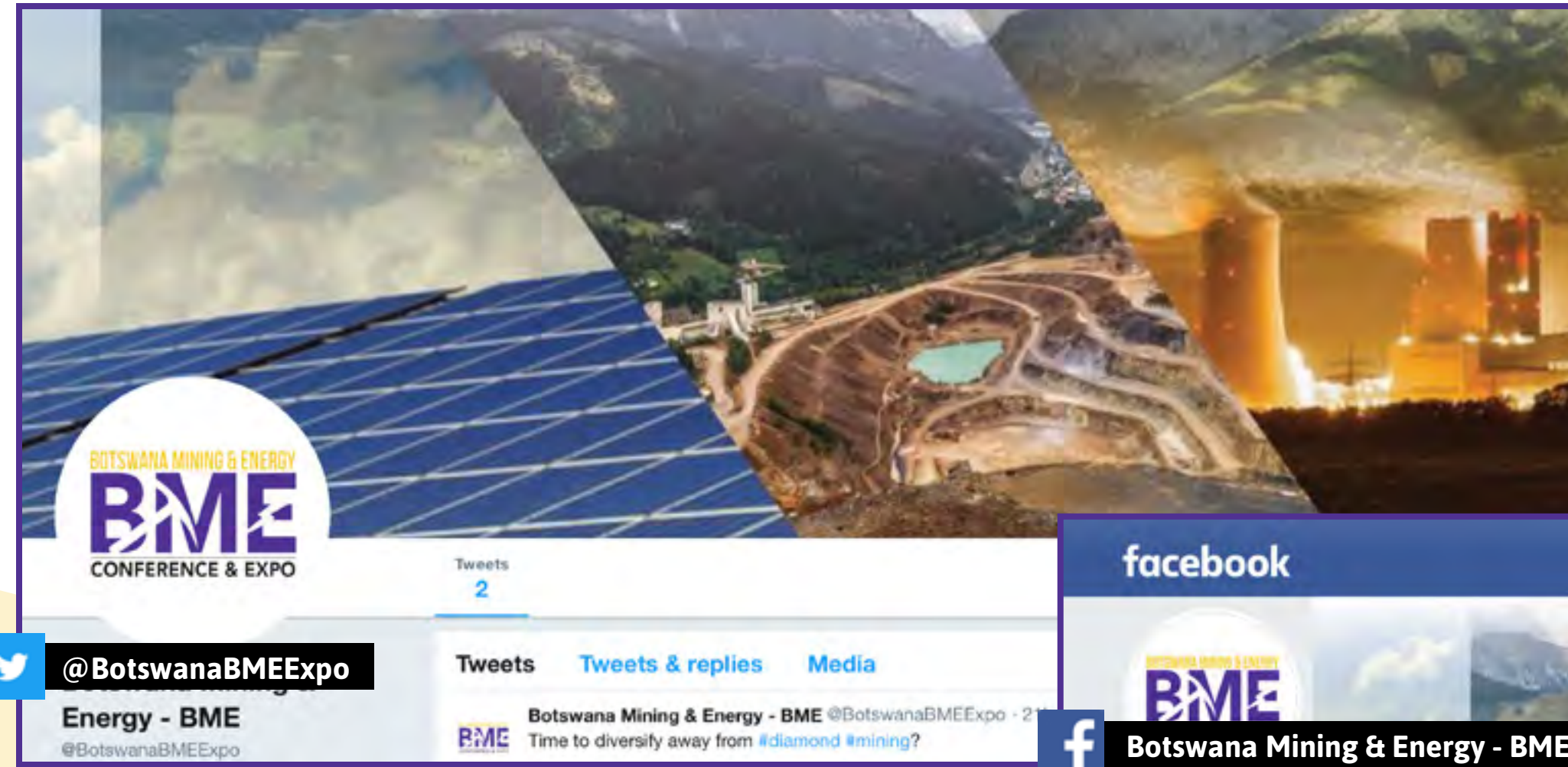

# MEET THE TEAM



**DANIEL RADZISZEWSKI**

Sponsorship, exhibition & general queries

Tel: +65 9649 1062

[daniel.radz@spire-events.com](mailto:daniel.radz@spire-events.com)



**ANUCITA CYNTHIA**

Exhibition & registration queries

Tel: +91 91235 34429

[anucita.cynthia@spire-events.com](mailto:anucita.cynthia@spire-events.com)